



For more Hi-Fi manuals and set-up information
please visit www.hifiengine.com

ONKYO SERVICE MANUAL**Stereo Graphic Equalizer****MODEL EQ-25(B)**

UD	120V AC, 60Hz
UW	120V/220V AC, 50/60Hz

SAFETY-RELATED COMPONENT WARNING!!

COMPONENTS IDENTIFIED BY MARK  ON THE SCHEMATIC DIAGRAM AND IN THE PARTS LIST ARE CRITICAL FOR RISK OF FIRE AND ELECTRIC SHOCK. REPLACE THESE COMPONENTS WITH ONKYO PARTS WHOSE PARTS NUMBERS APPEAR AS SHOWN IN THIS MANUAL.

MAKE LEAKAGE-CURRENT OR RESISTANCE MEASUREMENTS TO DETERMINE THAT EXPOSED PARTS ARE ACCEPTABLY INSULATED FROM THE SUPPLY CIRCUIT BEFORE RETURNING THE APPLIANCE TO THE CUSTOMER.

TABLE OF CONTENTS

Item	Page
Specifications	2
Block diagram	2
Precautions	6
Exploded view parts list	6
Exploded view	7
Front panel facilities	8
System connections	8
Printed circuit board parts list	8
Using the level control	10
Schematic diagram	11, 15
Printed circuit board view	13
Packing procedures	17



SPECIFICATIONS

Input:	Input sensitivity (FLAT): 150mV
	Input impedance: 50 kohms
Output:	Output voltage (FLAT): 150mV
	Output impedance: 1.0 kohms
Max. input:	5 volts, 20Hz – 20 kHz, 0.05% THD
Frequency response:	10Hz to 35kHz (+0, -0.5dB)
Total harmonic distortion:	Less than 0.01% at 20Hz-20kHz, 1.5V output (FLAT)
Signal-to-noise ratio:	100 dB, 1.5V output, IHF-A input short
Adjustable range:	±12 dB
Gain:	0 dB
Semiconductors:	ICs: 11 TRs: 18 Diodes: 28 LEDs: 3
AC output:	200 watts (UNSWITCHED) (USA and Canada models only)
Power supply:	AC120V, 60Hz (USA, Canada) AC240V, 50Hz (Australia, U.K.) AC120/220V, 50/60Hz (Europe, others)
Dimensions:	435(W) x 73(H) x 255(D) mm
Weight:	3.3 kg., 7.3 lbs.

Specifications and features are subject to change without notice.

BLOCK DIAGRAM

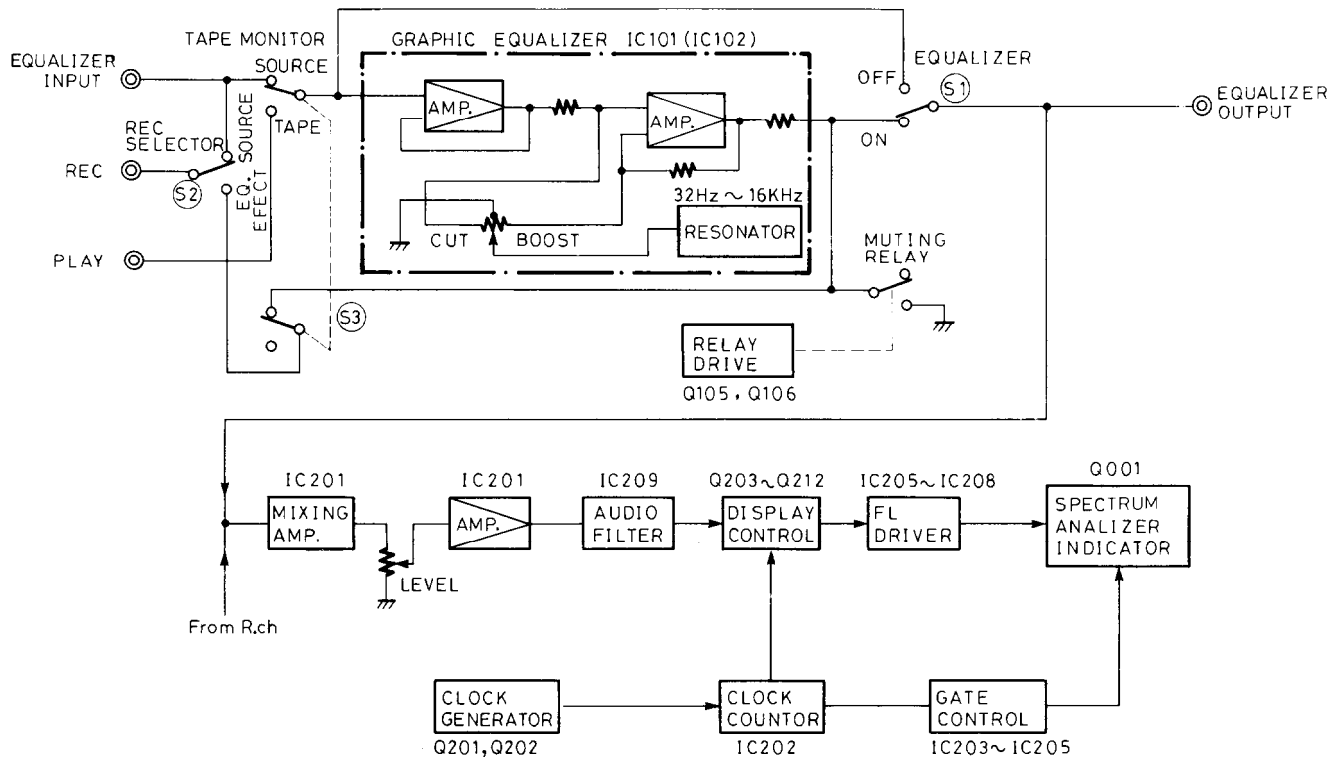

IC BLOCK DIAGRAM

NH-0065(L)
Graphic equalizer IC

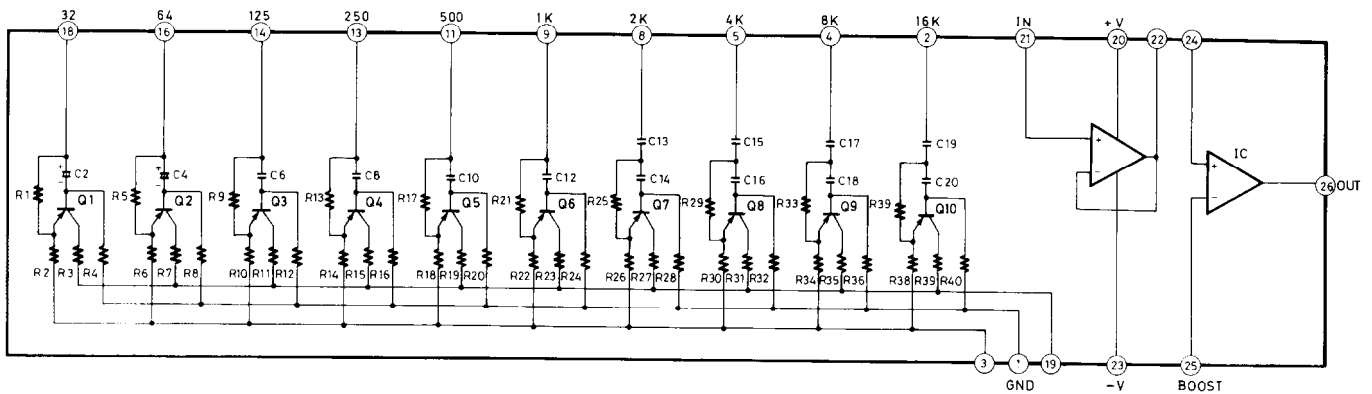

NH-0065(R)
Graphic equalizer IC

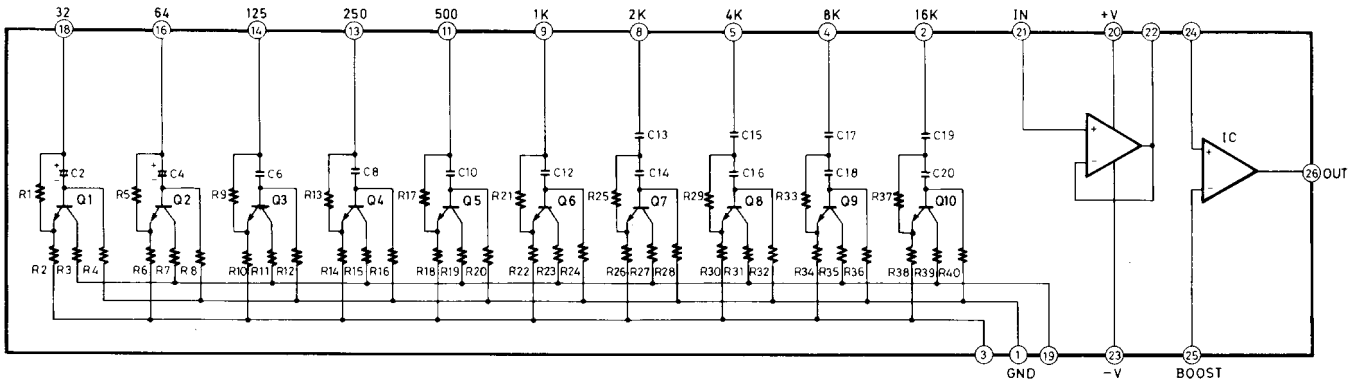

μPC339C
NJM2901N
Comparator

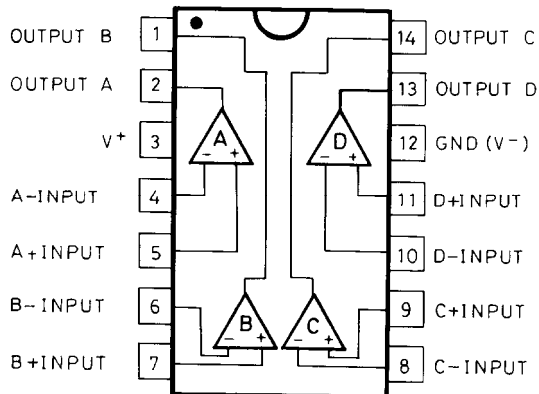

NJM4558
Dual Input Operational amplifier

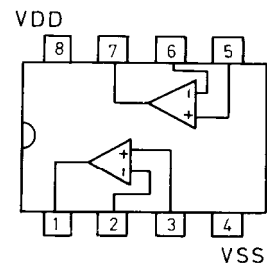

4017
Decade Counter/Divider

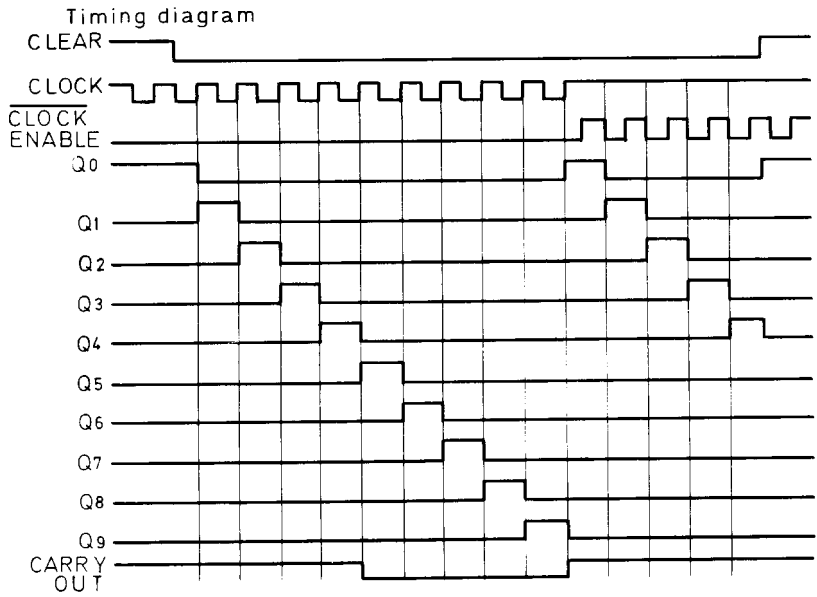
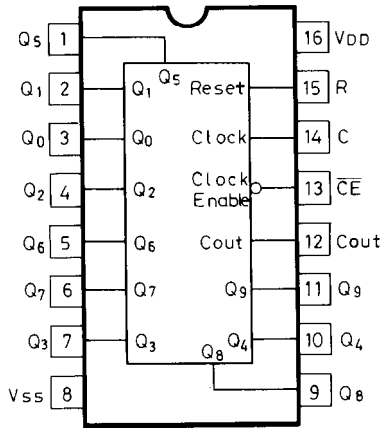

NH-0069(B.P.F.)
Band-Pass Filter

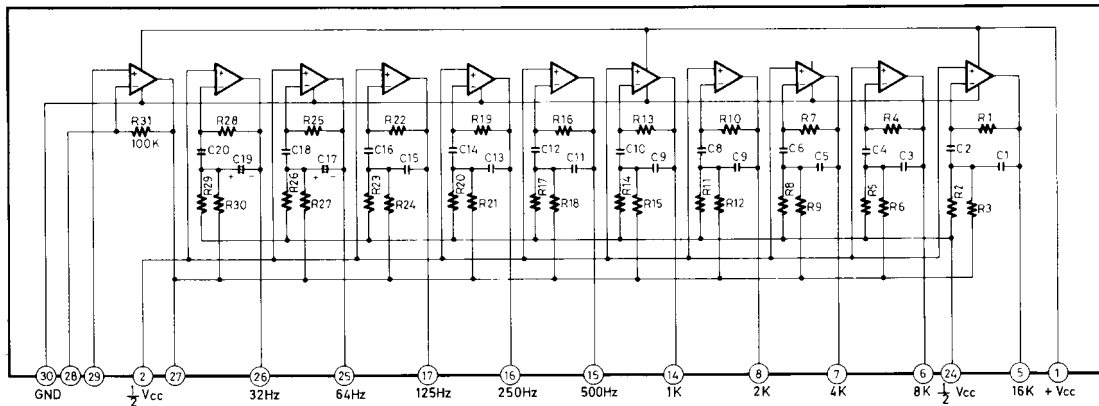

FIP10AWIGY
Fluorescent indicator tube

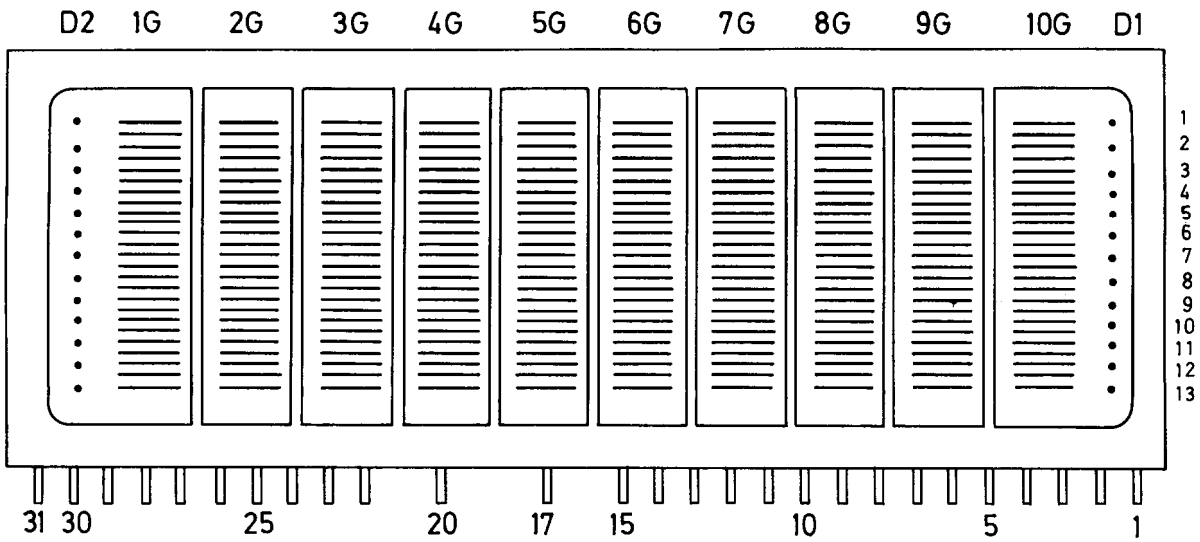

Pin No.	1	2	3	4	5	6	7	8	9	10	11
Electrode	F	F(D ₁)	10G	P(8)	P(9)	P(10)	9 G	P(11)	8 G	P(12)	P(13)

Pin No.	12	13	14	15	16	17	18	19	20	21	22
Electrode	7G	P(7)	P(6)	6G	NP	5G	NP	NP	4G	NP	P(5)

Pin No.	23	24	25	26	27	28	29	30	31
Electrode	3G	P(4)	2G	P(3)	P(2)	P(1)	1G	P(D ₂)	F

PRECAUTIONS

1. Insulation resistance measurement (Only U.S.A. model)

Connect the insulating-resistance tester between the plug of power supply cable and the terminal GND on the back panel. Specification; More than 10 MΩ at 500V.

2. Voltage selector (rear panel)

Some models are equipped with a voltage selector to conform with local power supplies. Be sure to set this switch to match the voltage of the power supply in your area before turning the power switch on. Voltage is changed by sliding the groove in the switch with a screwdriver or similar instrument to the right or left position.

Confirm that the switch has been moved all the way to the right or left before turning the power switch on. If there is no voltage selector switch on the unit you have purchased, it can only be used in areas where the power supply voltage is the same as that of the unit.



CHASSIS-EXPLODED VIEW-PARTS LIST

REF.NO.	PART NO.	DESCRIPTION	REF.NO.	PART NO.	DESCRIPTION
A1	27210612	Front panel ass'y	VR1	6142046	N30LLC100KW15ZX10, Slide variable resistor
A7	27141013	Bracket			
A8	27170207	Bottom board	VR2	6142047	N30LLC100KW15ZX10, Slide variable resistor
A10	27141015	Bracket, SW	△ S4	25035375	NPS-111-L339P, Power switch
A11	27141014	Bracket	△ P1	25050124	NSCT-2P27T, AC socket [D]
A13	27120726	Back panel [D]		25065228	NSS-2299, Slide switch [W]
	27120727	Back panel [W]	△ P2	253099	AS-UC-3, Power supply cable [D]
A14	28184276	Top cover		253083-1	AS-CEE, Power supply cable [W]
A17	28321905A	Knob, POW	△ P3	25060055	NTM-2PMN22, Terminal [W]
A18	28322151	Knob, GE	△ P4	27300750	Strainrelief
A19	28322152	Knob, EQ	U1	19328593	NAEQ-2393, Equalizer circuit pc board ass'y [D]
A20	28322153	Knob, REC		19320593A	NAEQ-2393A, Equalizer circuit pc board ass'y [W]
A21	28322154	Knob, TAPE	U2	19328592	NASW-2394, Equalizer switch pc board ass'y
A23	27273040	Joint, REC	U3	19328595	NALED-2395, LED circuit pac board ass'y
A24	27273041	Joint, TAPE	U4	19328596	NADG-2396, Spectrum analyzer drive circuit pc board ass'y
A25	880011	Rivet	U5	19328597	NADIS-2397, Spectrum analyzer indicator pc board ass'y
A30	28140627	Cushion	U6	19328598	NAVR-2398, Level variable resistor pc board ass'y
A31	27190390	Holder			
A34	27175066	Bottom leg			
A50	838430057	3STB+5S(BC), Tapping screw			
A52	831130067	3TTW+6S, Tapping screw			
A57	838430068	3TTB+6B(BC), Tapping screw			
△ T1	2300006	NPT-885D, Power transformer [D]			
	2300007	NPT-885DG, Power transformer [W]			
△ C136	3500083	XE303, Capacitor, IS [D]			
	8500065A	0.01 μF, AC125V/400V, Capacitor, IS [W]			
C136a	27300601	SB1925, Cover, capacitor for '136			

NOTE

[D]: Only 120V model

[W]: Only 120V/220V model

NOTE: THE COMPONENTS IDENTIFIED BY MARK △ ARE CRITICAL FOR RISK OF FIRE AND ELECTRIC SHOCK. REPLACE ONLY WITH PARTS NUMBER SPECIFIED.

CHASSIS-EXPLODED VIEW FRONT PANEL FACILITIES

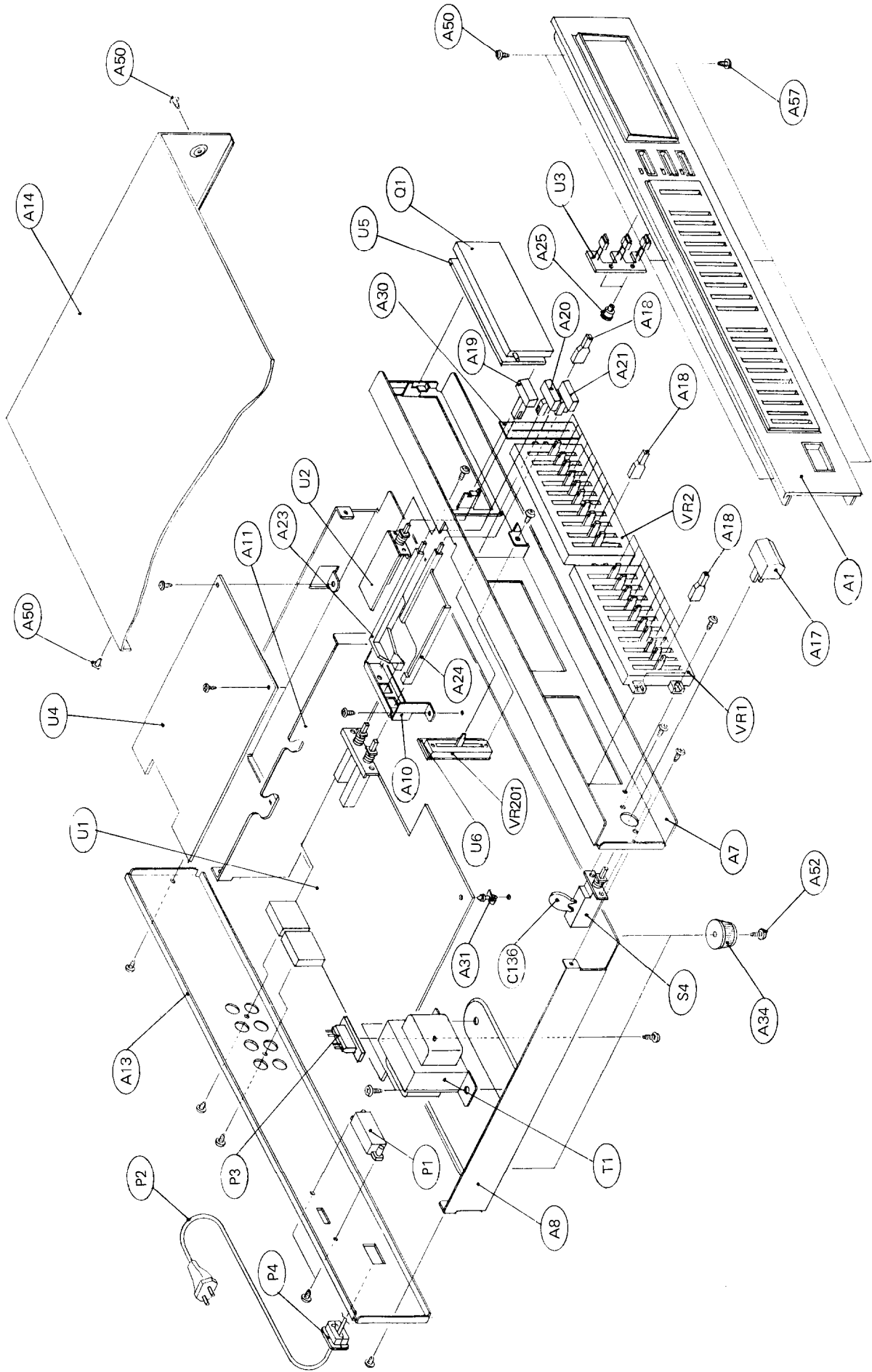

FRONT PANEL FACILITIES

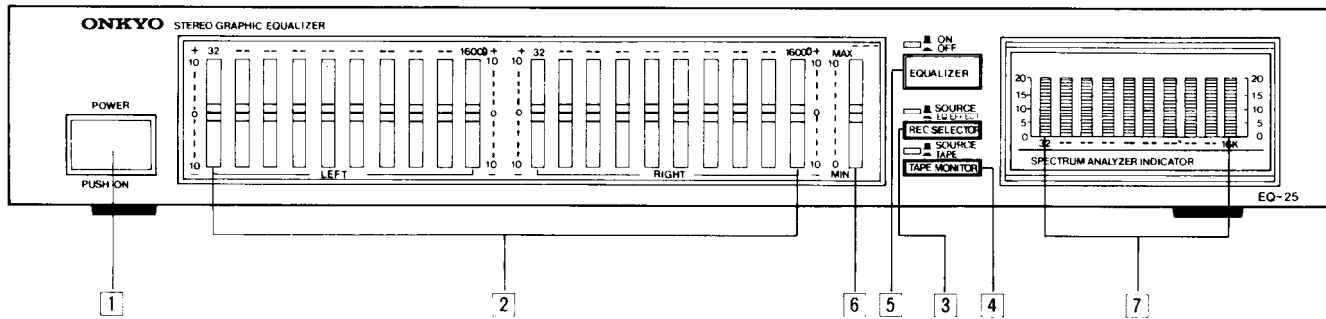

- 1 **Power switch (POWER)**
Depress once to turn power on and once again to turn power off.
- 2 **Level Controls**
Each control raises and lowers the response of the frequency range centered at the indicated frequency. Above the center '0' click-stop position, response is emphasized; below the '0' position, response is attenuated.
- 3 **Recording Selector and Indicator (REC. SELECTOR)**
Use this selector when recording on the tape deck connected to this unit. When set to the EQ. EFFECT position (—) (EQ. EFFECT indicator lights), the signal being recorded is altered according to the settings of the level controls. In the SOURCE position (■), the signal being recorded is unaffected by the level control settings.
- 4 **Monitor Switch and Indicator (TAPE MONITOR)**
Depress to the TAPE position (—) (TAPE indicator lights) to equalize the playback signal from the tape deck connected to the rear panel TAPE terminals. In the SOURCE position (■), the signal from the amplifier connected to the rear panel EQUALIZER INPUT terminals is input for equalization.
- 5 **Equalizer Switch and Indicator (EQUALIZER)**
Depress to the OFF position (—) to turn off the equalization effect set by the level controls. In the ON position (■) (EQ. indicator lights), the program source is equalized according to the settings of the level controls.
- 6 **Spectrum Analyzer Level Control (ANALYZER LEVEL)**
Use this control to adjust the signal level range shown by the spectrum analyzer. This control should be set to the point at which spectrum analyzer indications can be most easily read.
- 7 **Spectrum Analyzer Display**
This display shows the level of the program source in each frequency band. When the equalizer switch [5] is in the ON position, the signal levels after equalization are shown. When the equalization switch [5] is in the OFF position, the unequalized signal levels are shown.

SYSTEM CONNECTIONS

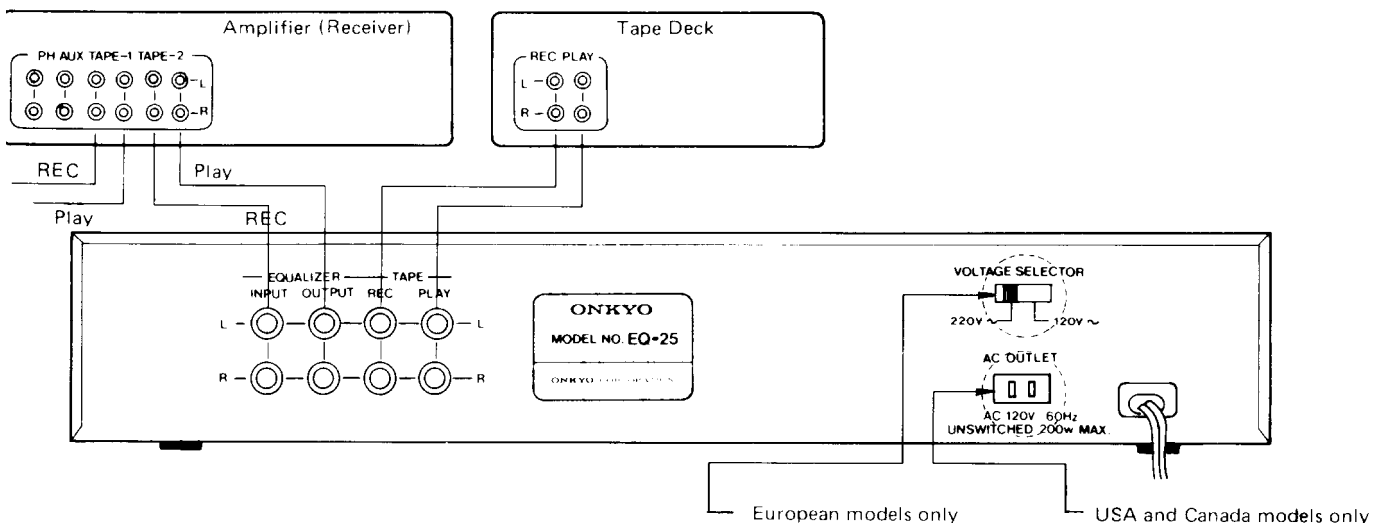

PRINTED CIRCUIT BOARD PARTS LIST

EQUALIZER CIRCUIT PC BOARD (NAEQ-2393, NAWQ-2393A) PARTS LIST

CIRCUIT NO.	PART NO.	DESCRIPTION
ICs		
IC101	222048	NH-0065(L)
IC102	222049	NH-0065(R)
Transistors		
Q101, Q106	2211255	2SC1815GR
Q102	2212771 or 2212772	2SD1585K or 2SD1585L
Q103, Q105	2211455	2SA1015GR
Q104	2212761 or 2212762	2SB1094K or 2SB1094L
Diodes		
D101	223892	DF02M
D102, D103	224075	HZ18-1
D104	223839	1N4002
D105	224312	HZ3C-1
D106, D107	223119	1S1588
Capacitors		
C101, C102	352761029	1000 μ F, 35V, Elect.
C103, C104	352752219	220 μ F, 25V, Elect.
C107, C108		
C105, C106	352754719	470 μ F, 25V, Elect.
C109	352744709	47 μ F, 16V, Elect.
C110	352752209	22 μ F, 25V, Elect.
C111, C120, C121, C124, C130	352750479	4.7 μ F, 25V, Elect.
C112, C113	379121035	0.01 μ F, 50V, DEW
C118, C119	352780109	1 μ F, 50V, Elect.
C120, C121, C124	352750479	4.7 μ F, 25V, Elect.
C122, C123	371124714	470 pF, 50V, MY
C125, C131	352780229	2.2 μ F, 50V, Elect.
C126, C132	352780159	1.5 μ F, 50V, Elect.
C127, C133	352786899	0.68 μ F, 50V, Elect.
C128, C134	352783399	0.33 μ F, 50V, Elect.
C129, C135	352781599	0.15 μ F, 50V, Elect.
C301, C303, C309, C311	371122214	220 pF, 50V, MY [W]
C302, C304, C310, C312, C313, C315	371123314	330 pF, 50V, MY [W]
C305, C307	371123914	390 pF, 50V, MY [W]
C306, C308	371126814	680 pF, 50V, MY [W]
C314, C316	371121014	100 pF, 50V, MY [W]
Resistors		
R103, R104	441624704	47 Ω , 1W, Metal oxide film
R105, R106	441621024	1 k Ω , 1W, Metal oxide film
R107	441622204	22 Ω , 1W, Metal oxide film
R108	441625614	560 Ω , 1W, Metal oxide film
Switches		
S2, (S3)	25035370	NPS-142-162-L334
Input terminals		
	25045167	NPJ-4PDBL61
Relay		
	25065255	RKT-12
Sockets		
	25050140	NJPS-3P-S
	25050141	NJPS-4P-S
	25050143	NJPS-6P-S
	25050144	NJPS-7P-S
Etc.		
	27160169	Radiator

EQUALIZER SWITCH PC BOARD (NASW-2394) PARTS LIST

CIRCUIT NO.	PART NO.	DESCRIPTION
S1	25035349	NPS-142-L312, Push switch

LED CIRCUIT PC BOARD (NALED-2395) PARTS LIST

CIRCUIT NO.	PARTS NO.	DESCRIPTION
L.E.D.s		
D108	225087	SEL1323G
D109, D110	225189	SEL1923D

SPECTRAM ANALYZER DRIVE CIRCUIT PC BOARD (NADG-2396) PARTS LIST

CIRCUIT NO.	PARTS NO.	DESCRIPTION
ICs		
IC201	222502	NJM4558DX
IC202	222840171	4017B
IC203 ~ IC208	222907 or 222908	μ PC339C or NJM2901N
IC209	222050	NH-0069 (B.P.F.)
Transistors		
Q201, Q202	2212125	2SA1048GR
Q203 ~ Q212	2212780	2SC2062
Diodes		
D201 ~ D221	223119	1S1588
Capacitors		
C202, C203	371126825	6800pF, 50V, MY
C205 ~ C219	352751009	10 μ F, 16V, Elect.
Resistors		
R216, (R217, R254, R240 ~ R243)	49121103507	10 k Ω X 7, Resistor array
R218, (R244, R245, R219 ~ R221)	29121103506	10 k Ω X 6, Resistor array
R222, (R223, R246, R250 ~ R252)		
R224, (R225, R253, R247 ~ R249)		
Sockets		
	25050140	NJPS-3P-S
	25050142	NJPS-5P-S

SPECTRUM ANALYZER INDICATOR PC BOARD (NADIS-2397) PARTS LIST

CIRCUIT NO.	PARTS NO.	DESCRIPTION
Q1	212029	FIP10AW19Y, Huores cent indicator tube

LEVEL VOLUME PC BOARD (NAVR-2398) PARTS LIST

CIRCUIT NO.	PARTS NO.	DESCRIPTION
VR201	6142045	N30LL100KB15Z, Slide variable resistor

NOTE

[W]: Only 120V/220V model

CHASSIS-EXPLODED VIEW FRONT PANEL FACILITIES

USING THE LEVEL CONTROL

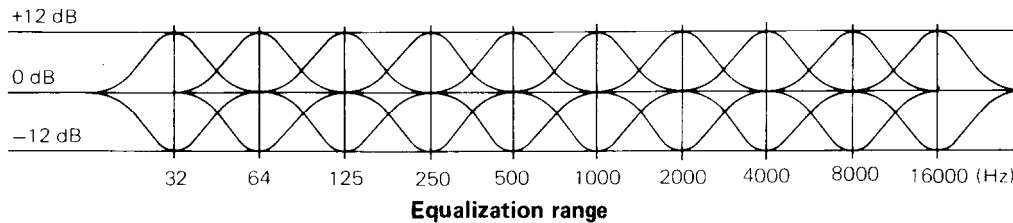

32 Hz

This frequency range is not found in records or pre-recorded tapes. It is felt more as a vibration or wave of pressure than as music. Lowering this level control is often an effective way to cut out motor noise, rumble and other unwanted low-frequency signal elements from a turntable.

64 Hz

This range includes the low rumbling sort of sounds created by a pipe organ or the lowest range of a piano. Lowering this level control eliminates humming noises from electric musical instruments, ventilation systems and other sources.

125 Hz

Frequencies around 125 Hz are the standard "base" tones with which most people are familiar. The position of this level control is very important because it has a major effect on the amount of "richness" or "body" in the music.

250 Hz – 500 Hz

These two frequency ranges contain most sounds from musical instruments and voices. Consequently, the positions of these two level controls determine the amount of power and warmth in the music.

1000 Hz

Sounds in this range seem to strike the face, giving the music a lively feeling that should be emphasized or attenuated according to the music program and listening environment.

2000 Hz

This frequency range contains the sounds that seem to pierce the ears to give trumpet notes their strength. Use this level control to adjust the power of this sort of music.

4000 Hz

Sounds in this range give music its sparkle. It is particularly important in controlling the clarity of high violin notes and other soft, high range tones.

8000 Hz

Adjusting this level control affects the barely audible high range tones that give music a feeling of detail. This is also the range where most tape noise is located so lowering this control is useful in suppressing annoying background hissing when listening to cassette tapes.

16000 Hz

Frequencies this high are mainly harmonics and overtones of other notes of musical instruments. Adjusting this level control affects the delicacy of the music and the sensation of the music "flowing" or "drifting."

OPERATIONS

Normal Equalization

- To equalize the signal from the amplifier, set the monitor switch [4] to the SOURCE position and the equalizer switch [5] to the ON position.
- To hear the unequalized signal from the amplifier, set the monitor switch [4] to the SOURCE position and the equalizer switch [5] to the OFF position.
- To equalize the signal from the tape deck connected to the rear panel tape terminals, set the monitor switch [4] to the TAPE position and the equalizer switch [5] to the ON position.
- To hear the unequalized signal from the tape deck connected to the rear panel tape terminals, set the monitor switch [4] to the TAPE position and the equalizer switch [5] to the OFF position.

Recording

- To record the equalized program source on the tape deck connected to the rear panel tape terminals, set the monitor switch [4] to the SOURCE position and the recording selector [3] to the EQ EFFECT position.
- To record the unequalized program source on the tape deck connected to the rear panel tape terminals, set the monitor switch [4] to the SOURCE position and the recording selector [3] to the SOURCE position. Note that if the tape deck has three heads, the just-recorded signal can be monitored.

Dubbing

- Tapes can be dubbed (copied) from the tape deck connected to the amplifier to the tape deck connected to the EQ-25. To perform dubbing, put the original tape in the deck connected to the amp and the blank tape in the deck connected to the EQ-25. Set the monitor switch [4] and the recording selector [3] to the SOURCE positions. Then set the amplifier to the dubbing mode and start playback of the first deck and recording of the second deck. If the amplifier is equipped for dubbing in either direction, the original tape can be put in the deck connected to the EQ-25 and the blank tape in the other deck.

The Spectrum Analyzer

The Spectrum analyzer shows the combined L/R signal level in each of the ten frequency bands. When the equalization function is being used (equalizer switch [5] is in the ON position), the spectrum analyzer shows the signal levels after equalization. When the equalization function is switched off (equalizer switch [5] is in the OFF position), the spectrum analyzer shows the signal levels without equalization. Raise the spectrum analyzer level control to make readings of weak signals more easily visible and lower the level control if the readings are too high.

SCHEMATIC DIAGRAM

(120V/220V Model)

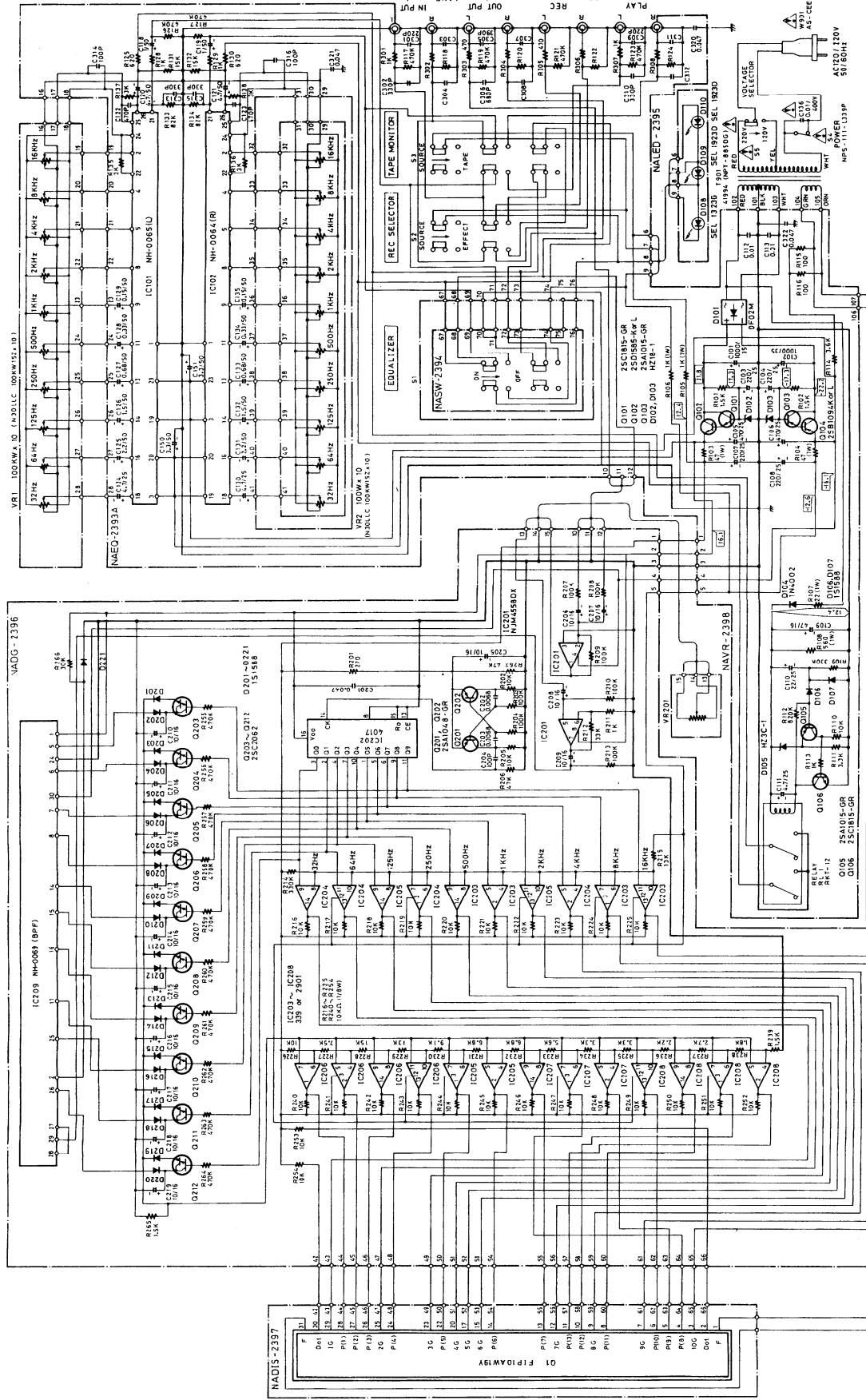

NOTES:
 1. RESISTORS ARE IN OHMS, UNLESS OTHERWISE NOTED.
 2. ALL CAPACITORS ARE IN P.F. UNLESS OTHERWISE NOTED.
 3. ELECTROLYTIC CAPACITORS (CAPACITORS IN P.F. ONLY) ARE IN P.F. ONLY.
 4. VOLTAGE MEASURED WITH V.T.M. (AC INPUT SIGNAL).
 5. OUTPUT IS SUBJECT TO CHANGE FOR IMPROVEMENT.
 6. PART NUMBERS IN CIRCLES ARE CRITICAL FOR SAFETY.
 7. REPLACE ONLY WITH PART NUMBER SPECIFIED.

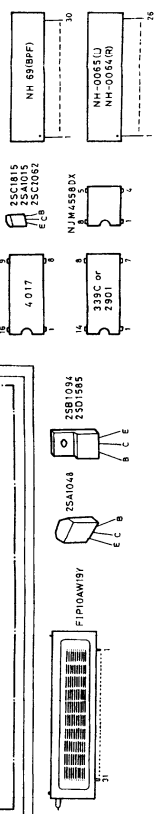

SCHEMATIC DIAGRAM

(120V Model)

1 2 3 4 5 6 7

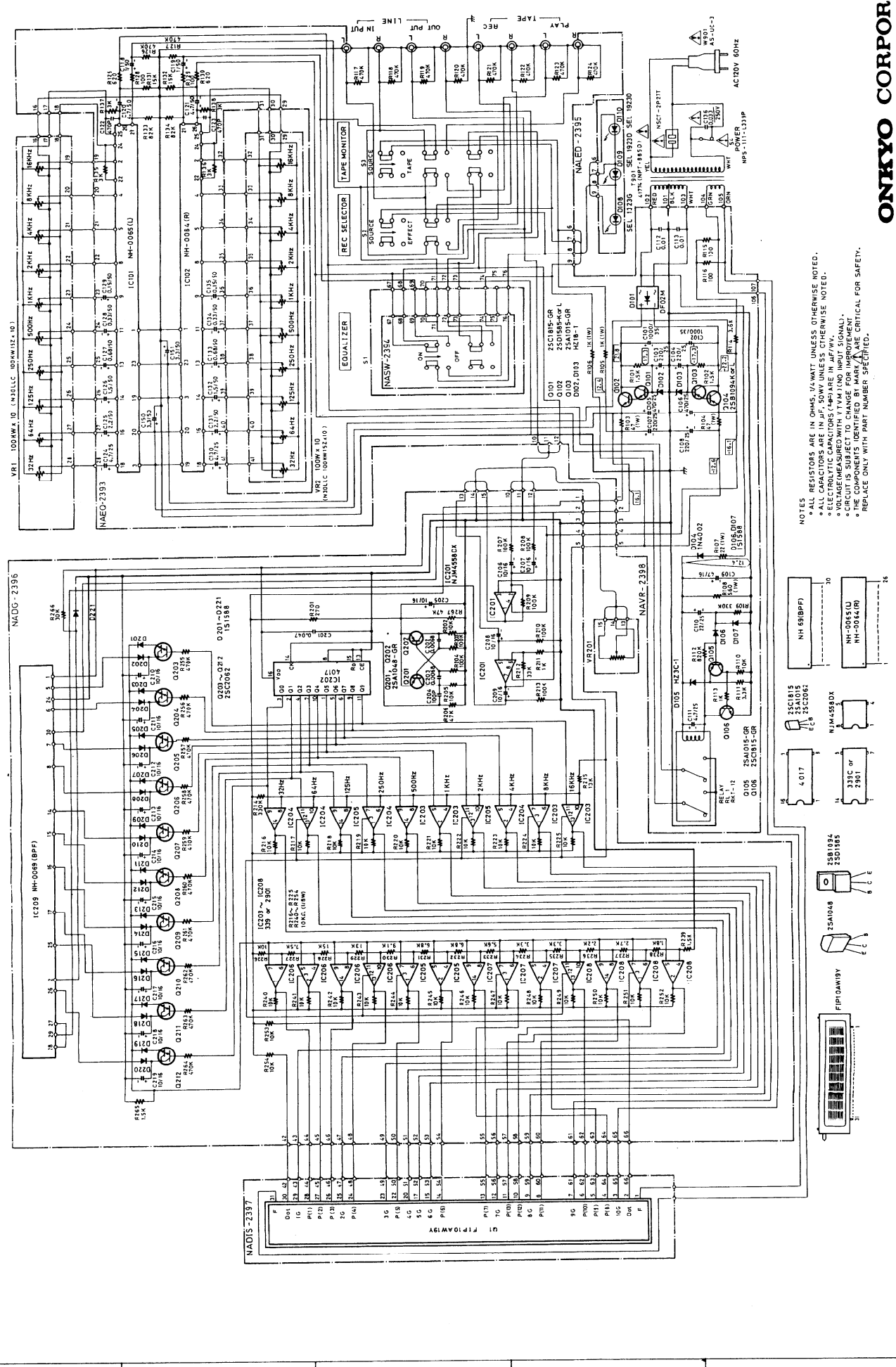

- NOTES
- ALL RESISTORS ARE IN OHMS, 1/4 WATT UNLESS OTHERWISE NOTED.
 - ALL CAPACITORS ARE IN μ F, 50V UNLESS OTHERWISE NOTED.
 - VOLTAGE MEASURED WITH TV TUNING INPUT SIGNAL.
 - CIRCUIT IS SUBJECT TO CHANGE FOR IMPROVEMENT.
 - THE COMPONENTS IDENTIFIED BY MARK ARE CRITICAL FOR SAFETY. REPLACE ONLY WITH PART NUMBER SPECIFIED.

ONKYO CORPORATION

— PACKING PROCEDURES

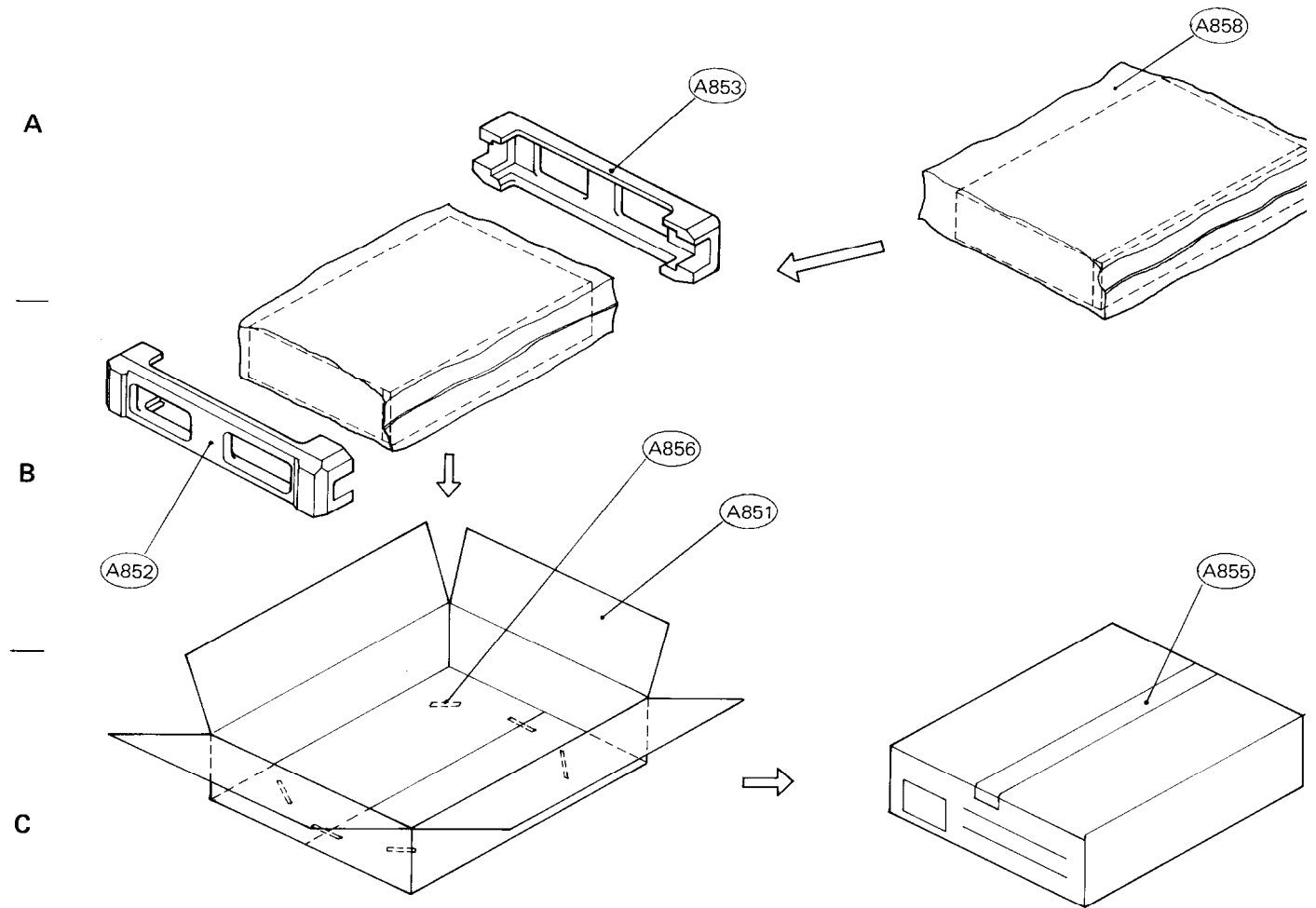

REF. No.	PART NO.	DESCRIPTION
A851	29051160	Master carton box
A852	29091012	Pad, left
A853	29091013	Pad right
A855	260012	Damplon tape
A856	282301	Sealing hook
A858	29100079	550 x 420, Poly bag
A880	Accessory bag ass'y	
	29340868	Instruction manual
	29365006-7	Warranty card [U]
	29358002C	Service station list [U]
	29100006A	350 x 250, Poly bag
	2010112	Connection cable
	25055040	CV-K-2 Conversion plug [W]

E

NOTE

- [U]: Only U.S.A. model
- [D]: Only 120V model
- [W]: Only 120V/220V model